



INTERSTATE-McBEE



**Core Reference Sheet
for Remanufactured Injectors
for Detroit Diesel[®], Cummins[®]
and Caterpillar[®]**



**4901 Lakeside Avenue
Cleveland, OH 44114-3996
Telephone: 800-321-4234
Telephone: 216-881-0015
Fax: 216-881-0805**

**Website: www.interstate-mcbee.com
e-mail: sales@interstate-mcbee.com**

Detroit Diesel® Injectors

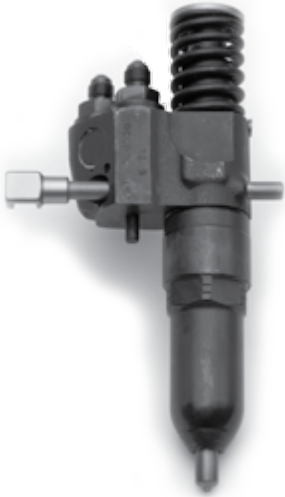

C-NC9

This is a standard Detroit, N, C, 53, 71, 92 Series injector style. Please note that the nut on the NC9 has two smaller grooves.

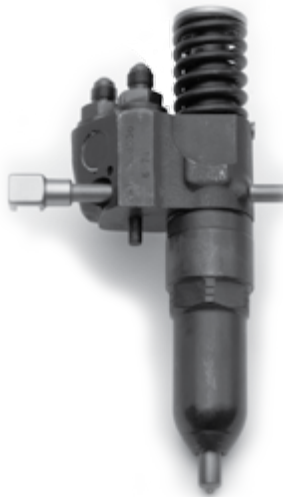

C-92E and C-92M

These cores look exactly the same as a C-NC9 core, but an C-NC9 core is not an acceptable return. The differences are internal, so always go by the part number of the injector.

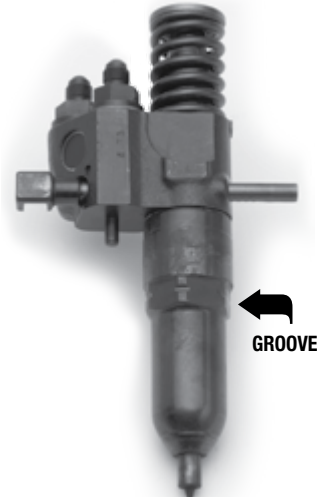

C-71S

This is a Detroit S injector core. Note that the body is similar to the C-NC9 core, but the nut on the S core has one large groove.



C-71H

This is a Detroit HV core. The body is different than an NC9, and the nut has one large groove.



C-82A, C-82B, C-82C

This is a Detroit 8.2L injector core. The 8.2L cores look the same, but the difference can be found by the letter stamped into the body clamp.

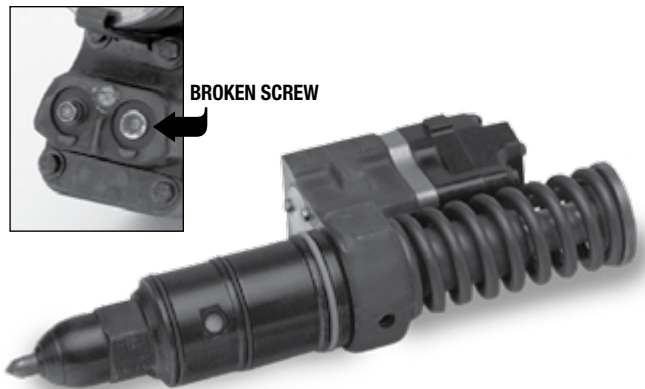

C-S60DDEC2, C-S60DDEC3/4

Each core can be identified by the tower of the body, underneath the spring. The C-S60DDEC2 core has two distinct steps and the C-S60DDEC3/4 has a tapered tower.

Series 60 cores with a broken or missing stator screw will not be accepted.



Cummins® Cores



C-PTD

This is a Cummins standard PTD core. Note that the spring is slightly exposed.



C-30B

This is a Cummins 5/16 PTD core. It is smaller than the standard PTD core with a more exposed spring.



C-41K

This is a Cummins K PTD core. This core is longer than the standard PTD core and the spring is much more exposed.



C-T/S

This is a Cummins standard Top Stop (T/S) core. Notice that the core does not have a visible spring on the top.



C-36B

This is a Cummins L10 T/S injector core. It is very similar to the standard T/S core, but the standard T/S is longer and wider than an L10 T/S. If in doubt, check the part number stamped on the injector.

CUMMINS SELECT CORES

FOR COMPLETE CORE CODE INFORMATION ON CUMMINS SELECT INJECTORS, REFER TO OUR REMANUFACTURED INJECTORS AND FUEL PUMPS PRICE LIST.

CORE RETURNS MUST MEET THE FOLLOWING CRITERIA:

- Units must be properly identified with their part number.
- Units must be returned as off of the engine – assembled and complete.
- Units damaged by fire will not be acceptable.

GROUP CLASSIFICATION OF CORES:

Cores will be accepted for any of the exchange injectors within the specific group classification. Unacceptable cores not meeting the above criteria will be scrapped and no credit will be issued.

Caterpillar® Cores



Caterpillar 7000 series core (ORXXXX)

These cores are only exchangeable by part number. For example if an R-0R3418 is purchased we must receive an 0R3418 or 8N7005 for exchange.



Caterpillar 7000 series cores with pushed in tips will not be accepted. Bent nozzles will also not be accepted. Any cores received with missing fuel lines will also not be accepted. Previously we could not accept any 7000 nozzle cores with a pushed out tip. Now some of these cores are acceptable but must measure within the specifications listed below.

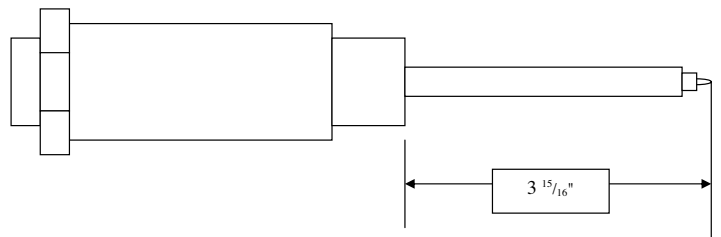

© Detroit Diesel is a registered trademark of the Detroit Diesel Corporation.
 © CUMMINS is a registered trademarks of Cummins, Inc.
 © Caterpillar and CAT are registered trademarks of Caterpillar, Inc.
 Prices are subject to change without notice.

*All manufacturer's names, numbers, symbols and descriptions are used for reference purposes only and does not imply that any part listed is the product of these manufacturers. Cores must be returned freight prepaid, with appropriate documents, to the factory in Cleveland, Ohio.



INTERSTATE-McBEE



Core Returns:

Cores must be returned as removed from the engine; assembled and complete. Units damaged by fire or rust will not be accepted. Cores will be accepted for any of the exchange injectors within the specific group classification. All core returns must be sent freight prepaid to 4901 Lakeside Avenue, Cleveland, Ohio 44114, Attn: Core Return Department. A packing list must be included with all core returns. Information such as company name, address, contact person is required. Details such as a list of the core quantity returned, core type, order or invoice numbers are also required. Copies of order packing list or our invoice are acceptable forms of return paperwork. Credit will only be issued for cores owed and any additional cores received will either be scrapped or returned at the customer's expense. We will not "bank" any extra cores returned. Any deviation to these instructions will cause delay in processing the core credit.

INTERSTATE-McBEE, LLC

4901 Lakeside Avenue
Cleveland, OH 44114-3996 U.S.A.

Telephone: 800-321-4234

Telephone: 216-881-0015

Fax: 216-881-0805

Website: www.interstate-mcbee.com

e-mail: sales@interstate-mcbee.com